

THE SANDVIK DD422i DEVELOPMENT DRILL

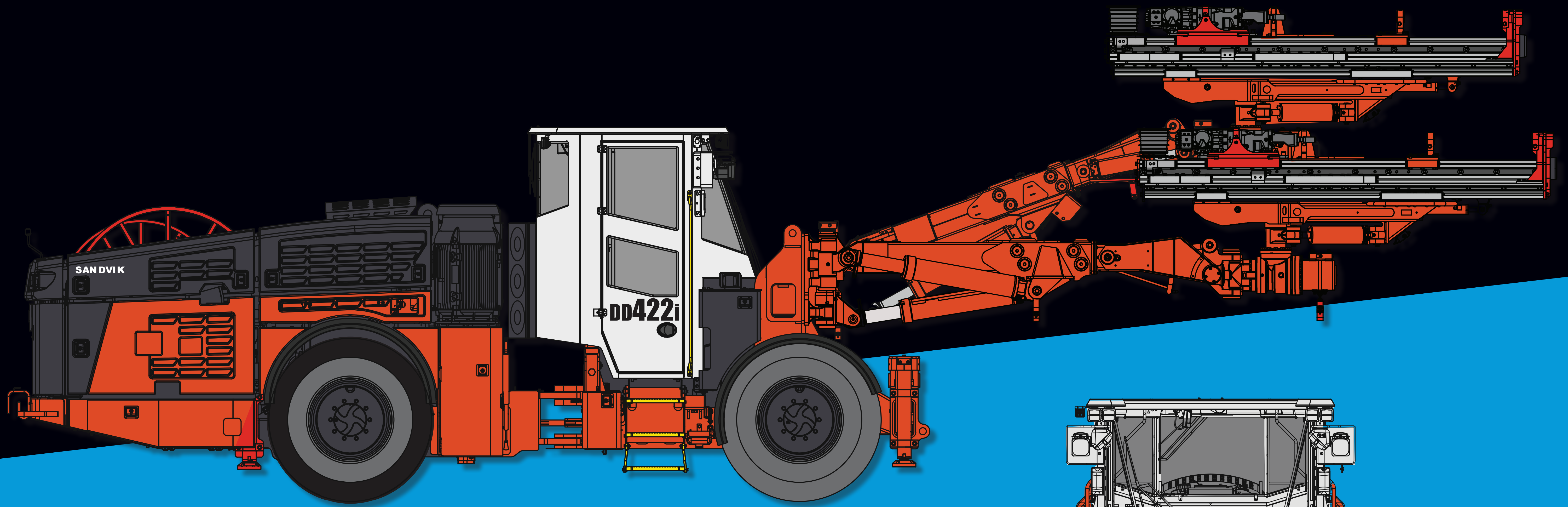

The Sandvik DD422i Development Drill is an enormous multipurpose drilling machine which is used at Fosterville Gold Mine.

It is equipped with an intelligent torque optimised drilling control system which helps to minimise hole deviation during drilling, reduce jammings and maximise the tool life and penetration rate.

FGM currently has five of these machines on site which are used day and night to advance the underground mining operation.

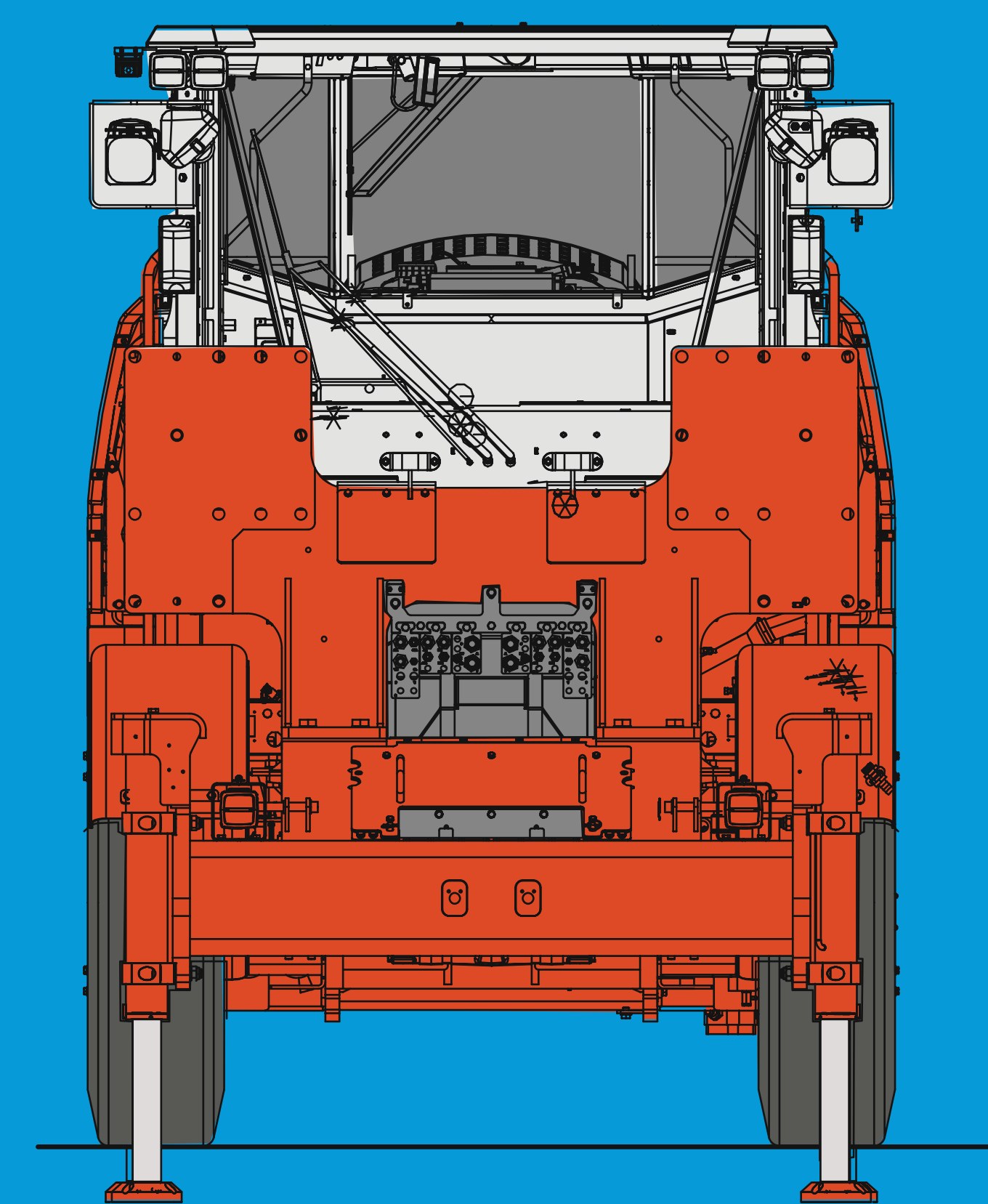

KEY FACTS



WEIGHT
26 tonnes



VALUE
Over \$2 million each



WIDTH
2.31m

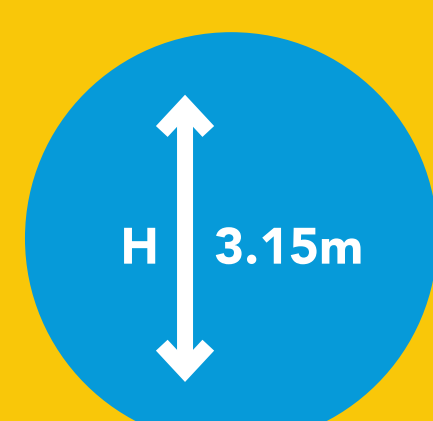

HEIGHT
3.15m

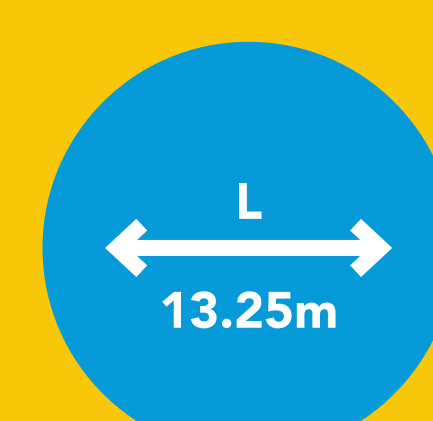

LENGTH
13.25m

KEY BENEFITS



**LOW EMISSION
DIESEL ENGINE**



**A PATENTED
SEMI-AUTOMATIC
DRILL BIT CHANGER**



**A LIGHT AND COMPACT
TELE-REMOTE
CONTROL STATION**

to allow the drill to be operated during shift changes, blasting and ventilation times.



AGNICO EAGLE
FOSTERVILLE